



Product Features:

- DC/DC Converter
- Custom Package Measuring 6.00" x 3.23" x 1.89"
- Integral Power Entry Module with Switch
- Convection Cooling (No Fans)
- Meets FCC & EN Class B EMI
- Worldwide Safety Approval (UL, CE, CB)



Input Specifications:

VOLTAGE	+18VDC~+60VDC
INRUSH	30A @ +48VDC Input / 3.25A output
CURRENT	
EFFICIENCY	≥80%
HARMONICS	EN61000-3-2 Class D Compliant (>98PF)

Output Specifications:

Vout	24VDC
Iout	3.25A
ADJUSTMENT RANGE	25.4VDC~31.2VDC
LINE REGULATION	±0.5% Max over entire input range
LOAD REGULATION	±0.5% Maximum
TEMP REGULATION	±0.5% Maximum
RIPPLE	≤ 240mVp-p
SETPOINT ACCURACY	±0.5%
OVER CURRENT	150~200%
OVER VOLTAGE	110~130%
PROTECTION	

General Specifications:

OPERATING TEMP	0°C to +50°C
STORAGE TEMP	-40°C to +85°C
OPERATING HUMIDITY	5% to 90% (Non-Condensing)
STORAGE HUMIDITY	5% to 95% (Non-Condensing)
COOLING	Convection cooling
VIBRATION	10-55Hz, 2G, 3min period/60 min each(3 axes)
SHOCK	20G Peak Acceleration
RELIABILITY	>100,000 Hrs MTBF
ALTITUDE	0~10,000 Feet
SIZE(W×D×H)	152.4mm x 82mm x 48mm

Electromagnetic Compatibility:

EMISSIONS	EN55022 Level B (Conducted)
ELECTROSTATIC DISCHARGE	EN61000-4-2, 4KV Contact / 8KV Air
RADIATED SUSCEPTIBILITY	EN61000-4-3, 26-1000MHz, 10V/M, 80%AM
EFT/BURSTS	EN61000-4-4, 2KV
SURGE	EN61000-4-5, 2kV Earth, 1kV Line-Line
CONDUCTED IMMUNITY	EN61000-4-6, 0.15-800MHz, 10V 80%
VOLTAGE DIPS	EN61000-4-10, 95% Dip&10ms, 30% Dip&500ms
VOLTAGE INTERRUPTIONS	EN61000-4-11, 95% reduction, 5ms
FLUCTUATIONS & FLICKER	EN61000-3-3

Standards & Approvals: TBD

UL/CUL	UL 60950-1
CE MARK	Electromagnetic Compatibility
CB	IEC 60950-1

Outline Drawing:

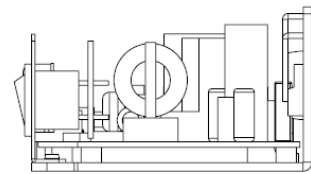
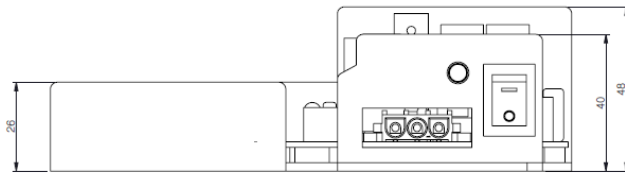
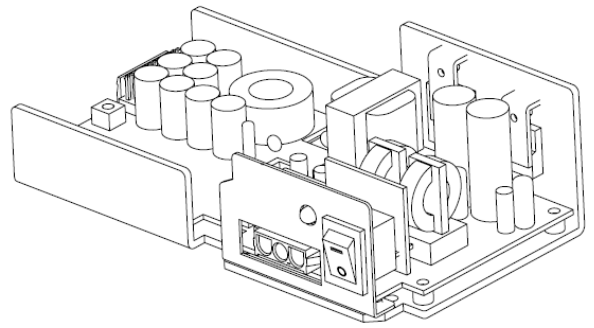
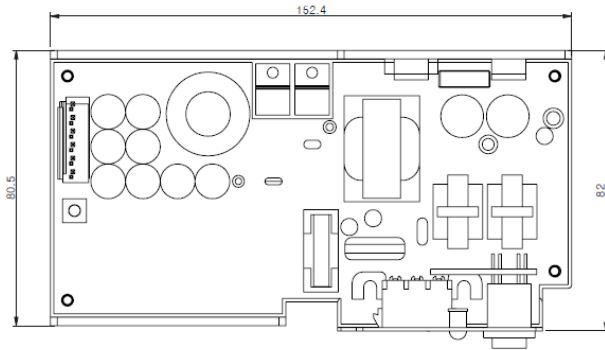

DONGAH ELECOMM

www.dongahelcomm.co.kr
www.dongahusa.com

DongAh Elecomm Corp.
134-14, Nampyeong-ro, Yangji-myun, Cheoin-gu,
Yongin-si, Kyunggi-do, 17162 Korea

DongAh Elecomm USA
275 W. Campbell Rd, Ste 320
Richardson TX 75080 U.S.A

Tel : +82-31-330-5500
Fax : +82-31-330-9040
Email : sales@dongahelcomm.co.kr

Tel : +1-972-497-9990
Fax : +1-972-497-9991
Email : sales@dongahusa.com